

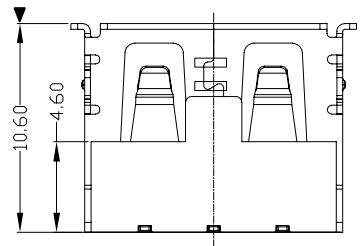

RoHS
Compliant
2002/95/EC

REV	LTR	DESCRIPTION	DATE	REVISER	APPD

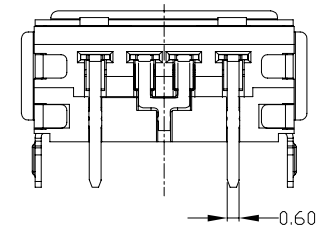
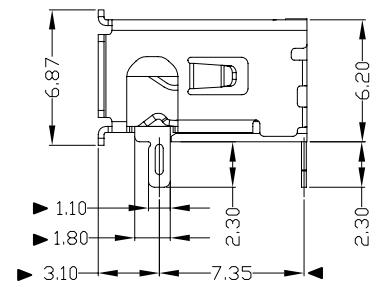
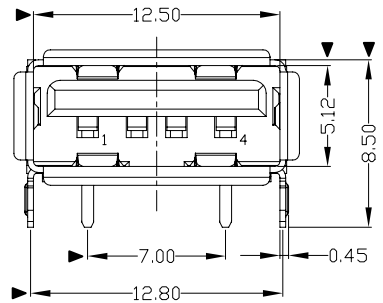
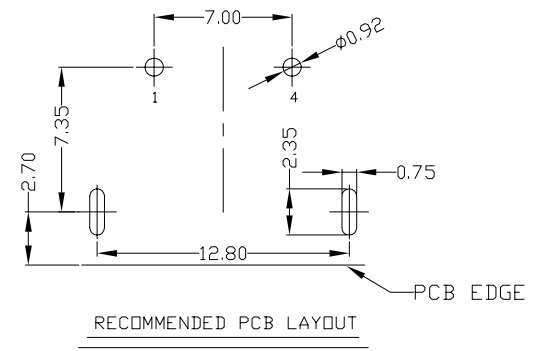
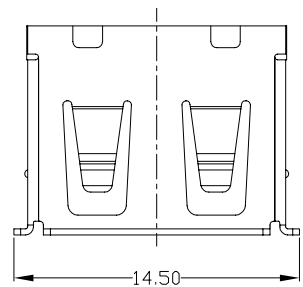

- NOTES:
- ELECTRICAL:
 - VOLTAGE CURRENT RATING: 2AMP, 30V AC;
 - INSULATION RESISTANCE: 1000MΩ, MIN;
 - CONTACT RESISTANCE: 30mΩ MAX;
 - WITHSTANDING VOLTAGE: 500V AC;
 - OPERATING TEMPERATURE: -55°C TO +85°C.
 - Mechanical:
 - Mating Force: 35N MAX
 - Unmating Force: 10N MIN.
 - NOTE: 1. DIMENSIONS MARKED "▼" TO BE CHECKED BY Q.C & IPQC.

4. PART NO.
USAF-04*N-1*R625

1-Au 1U*
6-Au 30U*

W: WHITE
B: BLACK

1-PBT
2-PA6T
3-PA9T
4-LCP

Bill of materials:

NO	PARTS	MATERIAL	QTY	FINISHING	UNITS	mm	雅安科技有限公司 ACCURATE INNOTECH INC.					
3	HOUSING	PBT+30%GF	1	UL94V-0	X. ±0.35	X.* ±2'	TITLE: USB AF DIP 90度 10.6二三短路2P	PART NO.: USAF-04*N-1*R625			DWG NO.: AII-R625	
2	SHELL	COPPER ALLOY/SPCC	1	PLATED NICKEL	.X ±0.30	.X* ±1'						DR: gan 2013/5/9
1	TERMINAL	COPPER ALLOY	4	PLATED GOLD/TIN	.XX ±0.25	.XX*						CHKD: gan 2013/5/9
NO	PARTS	MATERIAL	QTY	FINISHING	.XXX ±0.15	.XXX*	APPD: gan 2013/5/9	SCALE: 1:1	SHEET: 1/1	REV: B	CUSTOMER DRAWING	

THESE DRAWINGS AND SPECIFICATIONS ARE THE PROPERTY OF ACCURATE INNOTECH INC AND SHALL NOT BE REPRODUCED, COPIED OR USED IN ANY MANNER WITHOUT THE PRIOR WRITTEN CONSENT OF ACCURATE INNOTECH INC.

