

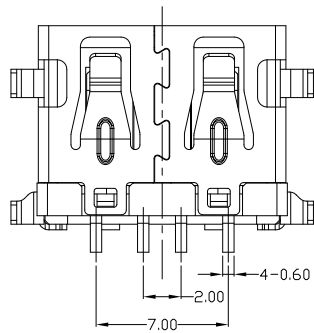

RoHS  
Compliant  
2002/95/EC

REV.	ECN. NO.	APPD.

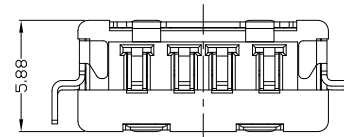
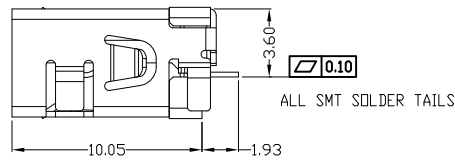
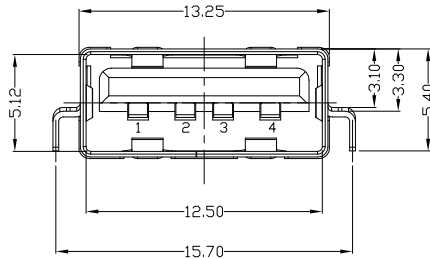
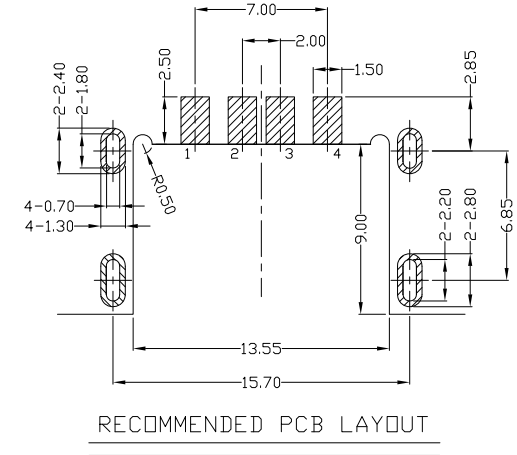
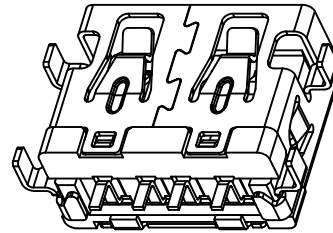
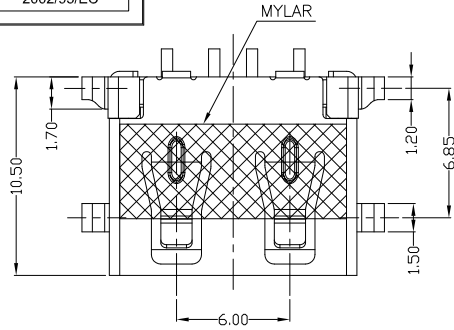

NOTES:

- ELECTRICAL:
  - VOLTAGE CURRENT RATING: 2AMP, 30V AC;
  - INSULATION RESISTANCE: 1000MΩ MIN;
  - CONTACT RESISTANCE: 30mΩ MAX;
  - WITHSTANDING VOLTAGE: 500V AC;
  - OPERATING TEMPERATURE: -25°C TO +85°C.
- Mechanical:
  - Mating Force: 35N MAX
  - Unmating Force: 10N MIN.
- NOTE: 1. DIMENSIONS MARKED "▼" TO BE CHECKED BY Q.C & IPQC.

4. PART NO.

USAF-041N-4BVS40

1: Au 1U\*  
5: Au 15u\*  
6: Au 30U\*

1: PBT  
2: PA6T  
3: PA9T  
4: LCP

W: WHITE  
B: BLACK  
G: GRAY

Bill of materials:

NO	PARTS	MATERIAL	QTY	FINISHING	X.	X.* ±2*	UNITS	雅安科技有限公司 ACCURATE INNOTECH INC.
					±0.35	mm		
3	HOUSING	LCP+30%GF	1	UL94V-0	.X ±0.3	.X* ±1*	MAT'L	TITLE: USB2.0 AF SMT 沉板 H3.6 带唛眼
2	SHELL	COPPER ALLOY	1	PLATED NICKEL	.XX ±0.25	.XX*	SEE NOTE	
1	TERMINAL	COPPER ALLOY	4	PLATED GOLD/TIN	.XXX ±0.15	.XXX*	FINISH	DR: gan 2018/07/12
THESE DRAWINGS AND SPECIFICATIONS ARE THE PROPERTY OF ACCURATE INNOTECH INC AND SHALL NOT BE REPRODUCED, COPIED OR USED IN ANY MANNER WITHOUT THE PRIOR WRITTEN CONSENT OF ACCURATE INNOTECH INC							Q'TY	CHKD: gan 2018/07/12
								APPD:
								SCALE: 1:1
								SHEET: 1/1
								REV.: B
								CUSTOMER DRAWING