

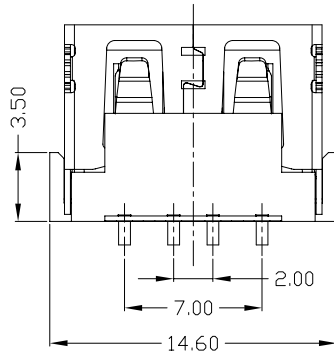

RoHS
Compliant
2002/95/EC

REV.	ECN.	NO.	APPD.

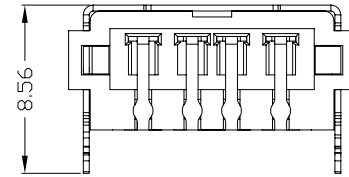
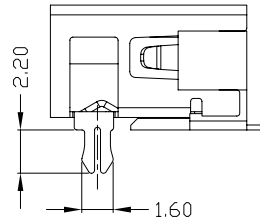
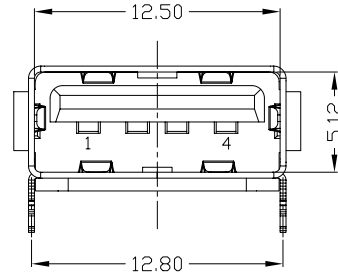
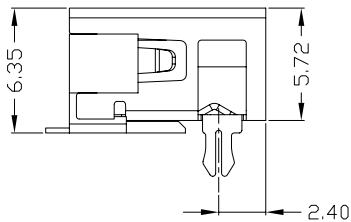
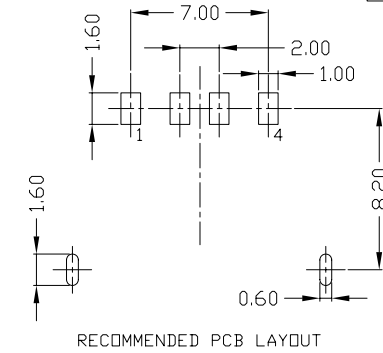
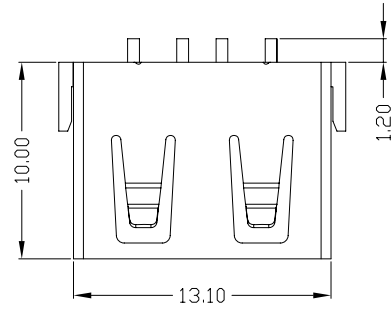

NOTES:

1. ELECTRICAL:

- 1) VOLTAGE CURRENT RATING: 2AMP, 30V AC;
- 2) INSULATION RESISTANCE: 1000MΩMIN;
- 3) CONTACT RESISTANCE: 30mΩMAX;
- 4) WITHSTANDING VOLTAGE: 500V AC;
- 5) OPERATING TEMPERATURE: -55°C TO +85°C.

2. Mechanical:

- 1) Mating Force: 35N MAX
- 2) Unmating Force: 10N MIN.

3. DIMENSIONS MARKED "▼" TO BE CHECKED BY Q.C & IPQC.

4. PART NO.

USAF-04*N-4*V612
 1:Au 1U*
 6:Au 30U*
 W:WHITE
 B:BLACK
 1:PBT
 2:PA6T
 3:PA9T
 4:PC

Bill of materials:

NO	PARTS	MATERIAL	QTY	FINISHING
3	HOUSING	LCP+30%GF	1	UL94V-0
2	SHELL	COPPER ALLOY	1	PLATED NICKEL
1	TERMINAL	COPPER ALLOY	4	PLATED GOLD/TIN

X. ±0.35	X.* ±2*	UNITS	mm
.X ±0.3	.X* ±1*	MAT'L	SEE NOTE
.XX ±0.25	.XX*	FINISH	SEE NOTE
.XXX ±0.15	.XXX*	Q'TY	SEE NOTE

雅安科技有限公司 ACCURATE INNOTECH INC.			
TITLE: USB AF SMT10.0 无卷边 外壳两前脚		PART NO.: USAF-04*N-4*V612	
DR: gan 2016/9/20		DWG NO.: AII-V612	
CHKD: gan 2016/9/20		SCALE	SHEET
APPD:		1:1	1/1
		REV. B	CUSTOMER DRAWING

THESE DRAWINGS AND SPECIFICATIONS ARE THE PROPERTY OF ACCURATE INNOTECH INC AND SHALL NOT BE REPRODUCED, COPIED OR USED IN ANY MANNER WITHOUT THE PRIOR WRITTEN CONSENT OF ACCURATE INNOTECH INC.