

REV	LTR	DESCRIPTION	DATE	REVISER	APPD
B	△	尺寸变更	10/12/02	ganqingwen	
C	△	尺寸变更	11/02/19	ganqingwen	

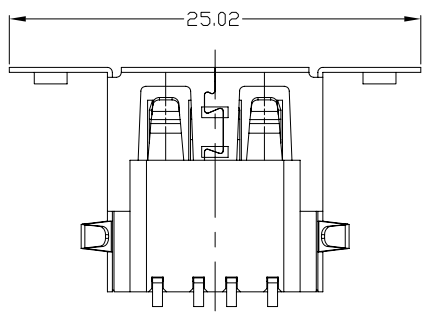
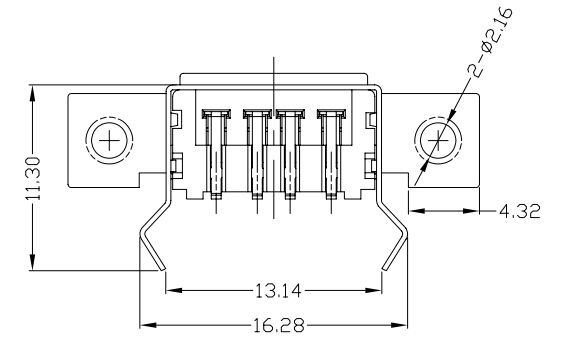
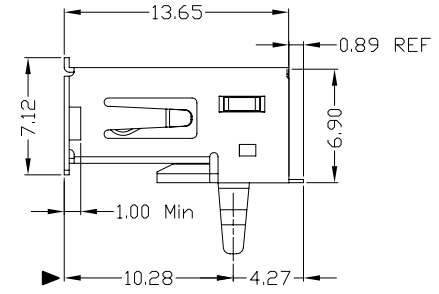
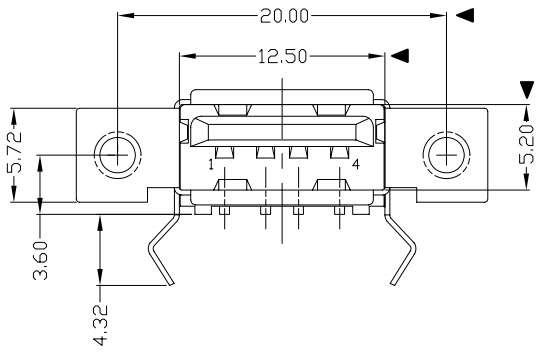
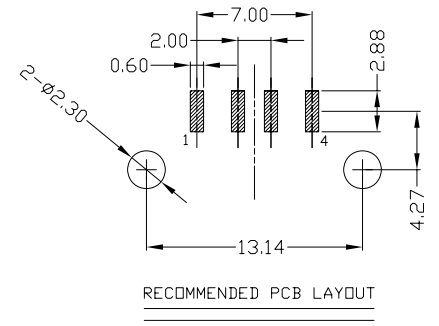
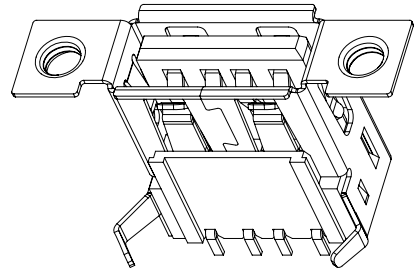
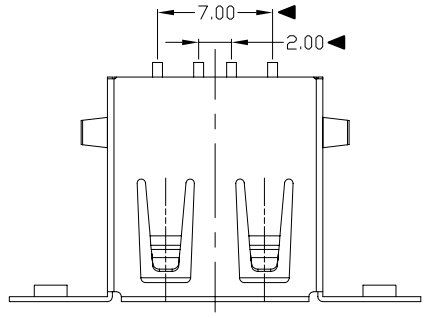

- NOTES:
- ELECTRICAL:
 - VOLTAGE CURRENT RATING: 2AMP, 30V AC;
 - INSULATION RESISTANCE: 1000MΩ MIN;
 - CONTACT RESISTANCE: 30mΩ MAX;
 - WITHSTANDING VOLTAGE: 500V AC;
 - OPERATING TEMPERATURE: -55°C TO +85°C.
 - Mechanical:
 - Mating Force: 35N MAX
 - Unmating Force: 10N MIN.
 - NOTE: 1. DIMENSIONS MARKED "▼" TO BE CHECKED BY Q.C & IPQC.

4.PART NO.
 USAF-04*N-4*V65
 1: Au 1U*
 6: Au 30U*
 W: WHITE
 B: BLACK
 1: PBT
 2: PA6T
 3: PA9T
 4: LCP

Bill of materials:

NO	PARTS	MATERIAL	QTY	FINISHING									
3	HOUSING	LCP	1	UL94V-0	X. ±0.35	X.' ±2'	UNITS	mm	雅安科技有限公司 ACCURATE INNOTECH INC. TITLE: USB A/F 90° SMT左右带螺孔 PART NO.: USAF-04*N-4*V65 DR: gan 2013/8/9 DWG NO.: AII-V65 CHKD: gan 2013/8/9 APPD:				
2	SHELL	COPPER ALLOY	1	PLATED NICKEL	.X ±0.3	.X' ±1'	MAT'L	SEE NOTE					
1	TERMINAL	COPPER ALLOY	4	PLATED GOLD/TIN	.XX ±0.25	.XX'	FINISH	SEE NOTE					
					.XXX ±0.15	.XXX'	Q'TY	SEE NOTE					
					THESE DRAWINGS AND SPECIFICATIONS ARE THE PROPERTY OF ACCURATE INNOTECH INC AND SHALL NOT BE REPRODUCED, COPIED OR USED IN ANY MANNER WITHOUT THE PRIOR WRITTEN CONSENT OF ACCURATE INNOTECH INC.								SCALE
										1:1	1/1	B	