

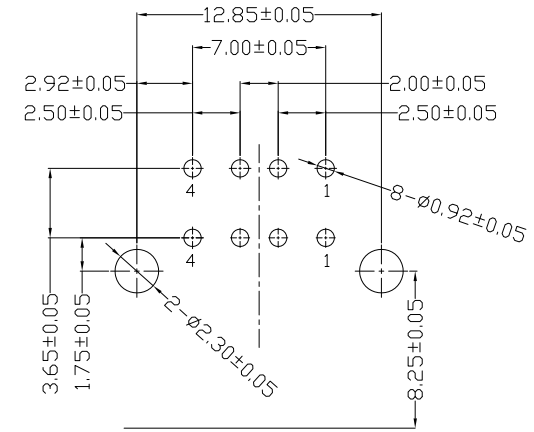

RoHS
Compliant
2002/95/EC

| REV | LTR | DESCRIPTION | DATE | REVISER | APPD |
|-----|-----|-------------|------|---------|------|
| | | | | | |

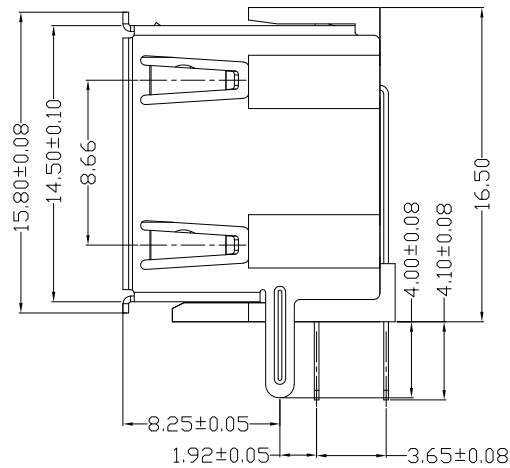
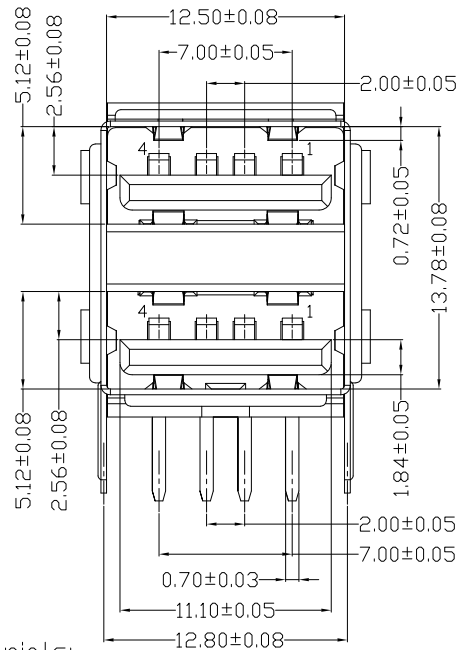
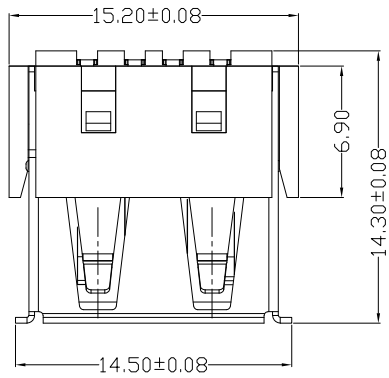

RECOMMENDED PCB LAYOUT

NOTES:

1.ELECTRICAL:

- 1)VOLTAGE CURRENT RATING:2AMP,30V DC;
- 2)INSULATION RESISTANCE: 1000MΩ MIN;
- 3)CONTACT RESISTANCE: 30mΩ MAX;
- 4)WITHSTANDING VOLTAGE: 500V AC FOR 1MIN;
- 5)OPERATING TEMPERATURE:-30°C TO +85°C.

2.Mechanical:

- 1)Mating Force: 35N MAX
- 2)Unmating Force: 10N MIN.

3.DIMENSIONS MARKED "▼"
TO BE CHECKED BY Q.C & IPQC.

4. PART NO.

USAF-08*N-1*RJ53

1:AU 1U"
6:AU 30U"

1:PBT
2:PA6T
3:PA9T
4:PC

Bill of materials:

| NO | PARTS | MATERIAL | QTY | FINISHING | X. | ±0.15 | X.' | ±5' | UNITS | mm |
|----|----------|---------------------|-----|-----------------|------|-------|-------|-------|----------|----|
| 5 | | | | | X. | ±0.15 | X.' | ±5' | MAT'L | |
| 4 | | | | | .XX | ±0.05 | .XX' | ±1' | SEE NOTE | |
| 3 | HOUSING | PBT+30%GF | 1 | | .XXX | ±0.03 | .XXX' | ±0.5' | FINISH | |
| 2 | SHELL | COPPER ALLOY / SPCC | 1 | PLATED NICKEL | | | | | SEE NOTE | |
| 1 | TERMINAL | COPPER ALLOY | 4 | PLATED GOLD/TIN | | | | | Q'TY | |

THESE DRAWINGS AND SPECIFICATIONS ARE THE PROPERTY OF ACCURATE INNOTECH INC. AND SHALL NOT BE REPRODUCED, COPIED OR USED IN ANY MANNER WITHOUT THE PRIOR WRITTEN CONSENT OF ACCURATE INNOTECH INC.

| 雅安科技有限公司 ACCURATE INNOTECH INC. | | PART NO.: | |
|------------------------------------|----------------------|------------------|----------|
| TITLE: | USB AF 双层短体90度 反向有卷边 | USAF-08XN-1XRJ53 | |
| DR: | Ricky 2019/08/21 | DWG NO.: | |
| CHKD: | Ricky 2019/08/21 | AII-RJ53 | |
| APPD: | | SCALE | SHEET |
| | | 1:1 | 1/1 |
| | | REV. | CUSTOMER |
| | | B | DRAWING |