

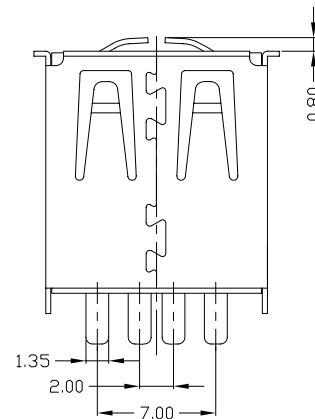

RoHS
Compliant
2002/95/EC

| REV. | ECN. | NO. | APPD. |
|------|------|-----|-------|
| | | | |
| | | | |

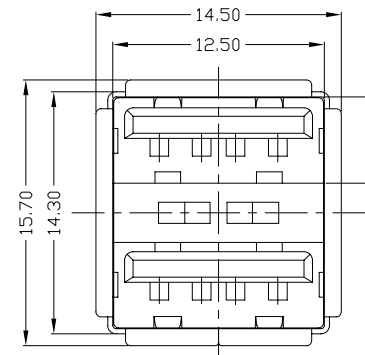
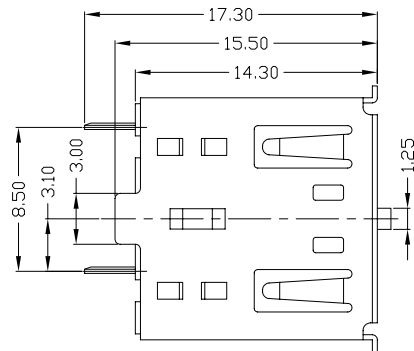

NOTES:

- ELECTRICAL:
 - VOLTAGE CURRENT RATING: 1AMP, 30V AC;
 - INSULATION RESISTANCE: 1000MΩMIN;
 - CONTACT RESISTANCE: 30mΩMAX;
 - WITHSTANDING VOLTAGE: 500V AC;
 - OPERATING TEMPERATURE: -55°C TO +85°C.
- Mechanical:
 - Mating Force: 35N MAX
 - Unmating Force: 10N MIN.
- DIMENSIONS MARKED "▼" TO BE CHECKED BY Q.C & IPQC.
- PART NO.

USAF-08*N-1*S37

1Au 1U*
6Au 30U*
V: WHITE
B: BLACK
1PBT
2PA6T
3PA9T
4LCP

Bill of materials:

| NO | PARTS | MATERIAL | QTY | FINISHING | UNITS | MAT'L | FINISH | Q'TY | TITLE: | PART NO.: | DR: | CHKD: | APPD: | SCALE | SHEET | REV. | CUSTOMER DRAWING |
|---|----------|--------------|-----|-----------------|------------|---------|----------------------|----------|-------------------------|-----------------|------------|-------|------------|-------|---------|------|------------------|
| 4 | CLIP | COPPER ALLOY | 1 | PLATED NICKEL | X. ±0.35 | X.* ±2* | SEE NOTE | SEE NOTE | 雅安科技有限公司 | USAF-08*N-1*S37 | gan | gan | | 1:1 | 1/1 | B | |
| 3 | HOUSING | PBT+30%GF | 1 | UL94V-0 | .X ±0.3 | .X* ±1* | SEE NOTE | SEE NOTE | ACCURATE INNOTECH INC. | USAF-08*N-1*S37 | gan | gan | | 1:1 | 1/1 | B | |
| 2 | SHELL | COPPER ALLOY | 1 | PLATED NICKEL | .XX ±0.25 | .XX* | SEE NOTE | SEE NOTE | USB AF 180° 双层短体焊线有脚双内弹 | USAF-08*N-1*S37 | gan | gan | | 1:1 | 1/1 | B | |
| 1 | TERMINAL | COPPER ALLOY | 8 | PLATED GOLD/TIN | .XXX ±0.15 | .XXX* | SEE NOTE | SEE NOTE | DR: gan 2015/09/21 | AII-S37 | gan | gan | | 1:1 | 1/1 | B | |
| THESE DRAWINGS AND SPECIFICATIONS ARE THE PROPERTY OF ACCURATE INNOTECH INC AND SHALL NOT BE REPRODUCED, COPIED OR USED IN ANY MANNER WITHOUT THE PRIOR WRITTEN CONSENT OF ACCURATE INNOTECH INC. | | | | | | | APPD: gan 2015/09/21 | | DWG NO.: AII-S37 | | SCALE: 1:1 | | SHEET: 1/1 | | REV.: B | | CUSTOMER DRAWING |