

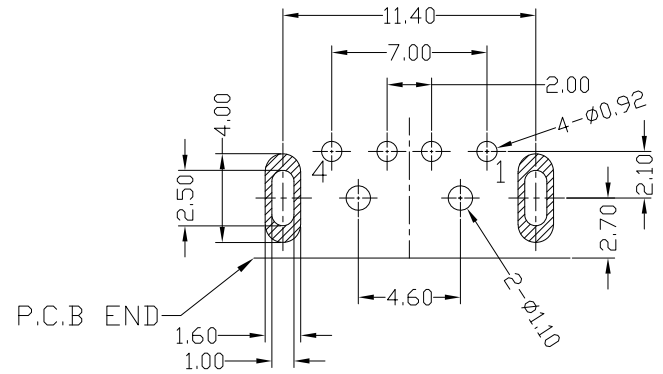

RoHS Compliant
2002/95/EC

REV.	ECN.	NO.	APPD.

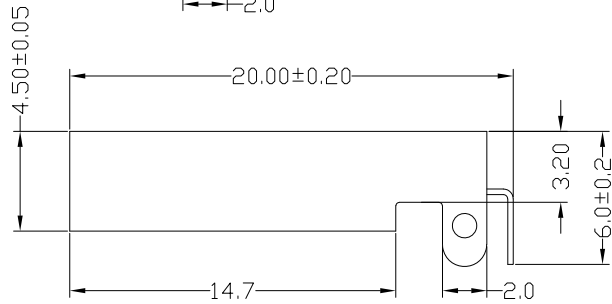
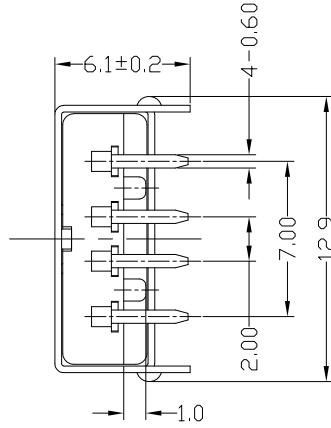
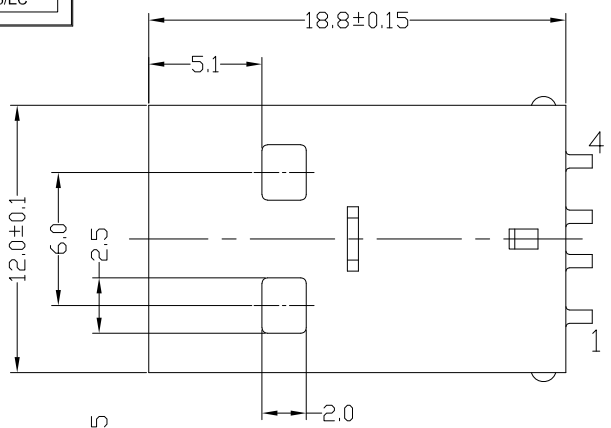

Recommend P.C.B Layout

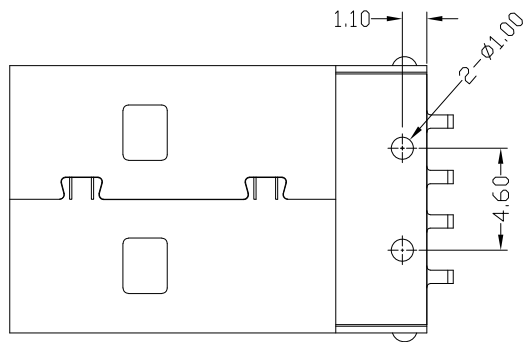

NOTES:

- ELECTRICAL:
 - VOLTAGE CURRENT RATING: 2AMP, 30V AC;
 - INSULATION RESISTANCE: 1000MΩ MIN;
 - CONTACT RESISTANCE: 30mΩ MAX;
 - WITHSTANDING VOLTAGE: 500V AC;
 - OPERATING TEMPERATURE: -45°C TO +85°C.
- Mechanical:
 - Mating Force: 35N MAX
 - Unmating Force: 10N MIN.
- DIMENSIONS MARKED "▼"
TO BE CHECKED BY Q.C & IPQC.

USAM-041N-1*R37

1: Au 1U*	W: WHITE
6: Au 30U*	B: BLACK
	1: PBT
	2: PA6T
	3: PA9T
	4: LCP

Bill of materials:

5					.X	±0.30	.X*	UNITS	mm
4					.XX	±0.20	.XX*	MAT'L	
3	HOUSING	PBT	1	UL94V-0	.XXX		.XXX*	SEE NOTE	
2	TERMINAL	COPPER ALLOY	4	PLATED GOLD/TIN				FINISH	
1	SHELL	SPCC	1	PLATED NICKEL				SEE NOTE	
NO	PARTS	MATERIAL	QTY	FINISHING				Q'TY	

THESE DRAWINGS AND SPECIFICATIONS ARE THE PROPERTY OF ACCURATE INNOTECH INC AND SHALL NOT BE REPRODUCED, COPIED OR USED IN ANY MANNER WITHOUT THE PRIOR WRITTEN CONSENT OF ACCURATE INNOTECH INC.

雅安科技有限公司 ACCURATE INNOTECH INC.			
TITLE: USB AM 90° DIP 直脚6.0打圆点		PART NO.: USAM-04XN-1XR37	
DR: <i>Ricky</i> 2023/06/26		DWG NO.: AII-R37	
CHKD: <i>Ricky</i> 2023/06/26		SCALE	SHEET
APPD:		1:1	1/1
		REV.	CUSTOMER DRAWING
		B	