

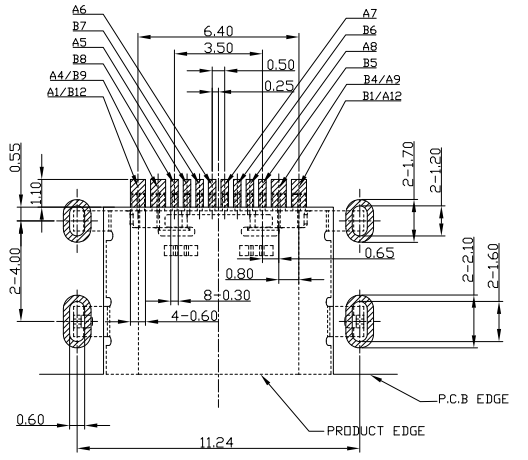

RoHS  
Compliant  
2002/95/EC

REV.	ECN.	NO.	APPD.

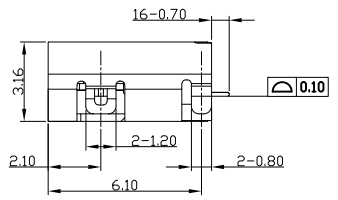
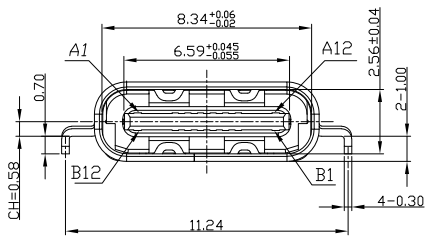
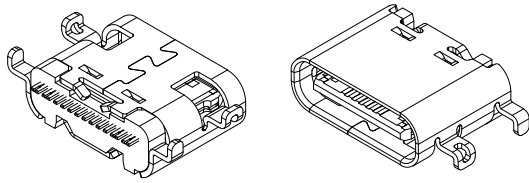
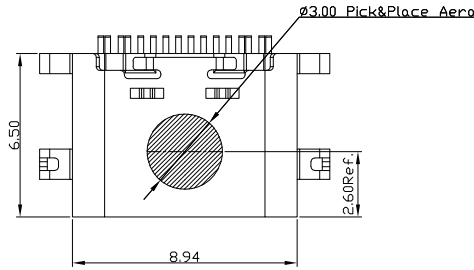

RECOMMENDED PCB LAYOUT (THICKNESS: 0.80MM)  
PWB TOLERANCE: ±0.05

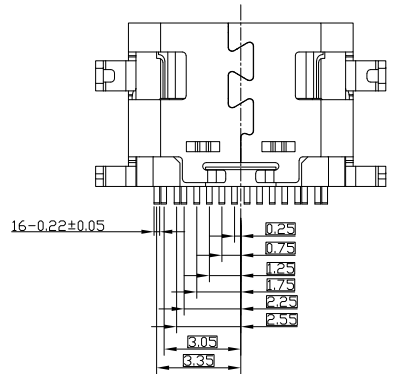

USB TYPE C PIN ASSIGNMENTS

PIN NUMBER	SIGNAL NAME	PIN NUMBER	SIGNAL NAME
A1	GND	B12	GND
A4	VBUS	B9	VBUS
A5	CC1	B8	SUB2
A6	Dp1	B7	Dn2
A7	Dn1	B6	Dp2
A8	SBU1	B5	CC2
A9	VBUS	B4	VBUS
A12	GND	B1	GND

NOTES:

- ELECTRICAL:
  - VOLTAGE CURRENT RATING: 3A~5A 5V
  - INSULATION RESISTANCE: 100MΩ MIN;
  - CONTACT RESISTANCE:
    - LLCR:VBUS & GND PINS AND OTHER PINS: 40mΩ/PIN MAX.
    - SHIELD:50mΩ/MAX.
    - LLCR MAX. CHANGE OF ALL PINS: 10mΩ.
  - WITHSTANDING VOLTAGE: 100V AC; FOR 1 MINUTE.
  - OPERATING TEMPERATURE:-25°C TO +85°C.
- Mechanical:
  - Mating Force: 5N~20N
  - Unmating Force: 8N~20N
  - Durability: 10,000 cycles
- DIMENSIONS MARKED "▼"  
TO BE CHECKED BY Q.C & IPQC.

4.PART NO.  
USCF-161N-3BVL29

1:Au 1U\*  
2:Au 3U\*  
5:Au 15U\*  
6:Au 30U\*

W:WHITE  
B:BLACK

1:PB  
2:PA6T  
3:PA9T  
4:LCP

Bill of materials:

NO	PARTS	MATERIAL	QTY	FINISHING	UNITS	mm	雅安科技有限公司 ACCURATE INNOTECH INC.							
4	FRONT SHELL	STAINLESS STEEL	1	PLATED NICKEL	X.	±0.45	X.	±5°	SEE NOTE	TITLE: USB TYPE CF 单排贴板 16P L=6.5 沉板1.0	PART NO: USCF-16XN-3BVL29	DR: Ricky 2021/08/13	DWG NO: AII-VL29	
3	MID PLATE	STAINLESS STEEL	1	PLATED NICKEL	.XX	±0.35	.XX	±2°						
2	CONTACT	COPPER ALLOY	16	PLATED GOLD/TIN	.XXX	±0.25	.XX	±1°	SEE NOTE	CHKD: Ricky 2021/08/13	SCALE	SHEET	REV.	CUSTOMER DRAWING
1	HOUSING	PA9T+30%GF	1	UL94V-0	.XXX	±0.15	.XXX	±0.5°						
NO	PARTS	MATERIAL	QTY	FINISHING						APPD:	1:1	1/1	B	

THESE DRAWINGS AND SPECIFICATIONS ARE THE PROPERTY OF ACCURATE INNOTECH INC AND SHALL NOT BE REPRODUCED, COPIED OR USED IN ANY MANNER WITHOUT THE PRIOR WRITTEN CONSENT OF ACCURATE INNOTECH INC.

