



**RoHS Compliant**  
2002/95/EC

USB TYPE-C PIN ASSIGNMENTS

PIN NUMBER	SIGNAL NAME	PIN NUMBER	SIGNAL NAME
A1	GND	B12	GND
A2	SSTXp1	B11	SSRXp1
A3	SSTXn1	B10	SSRXn1
A4	Vbus	B9	Vbus
A5	CC1	B8	SBU2
A6	Dp1	B7	Dn2
A7	Dn1	B6	Dp2
A8	SBU1	B5	CC2
A9	Vbus	B4	Vbus
A10	SSRXn2	B3	SSTXn2
A11	SSRXp2	B2	SSTXp2
A12	GND	B1	GND

REV.	ECN.	NO.	APPD.

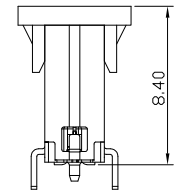
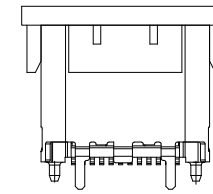
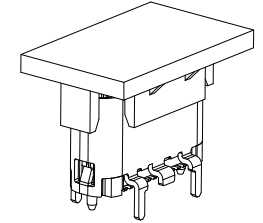
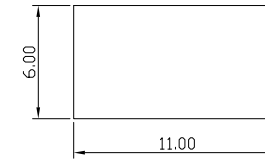
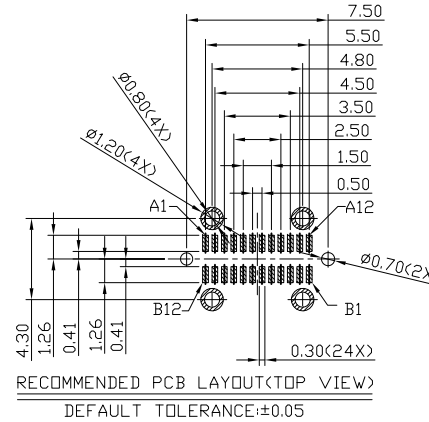
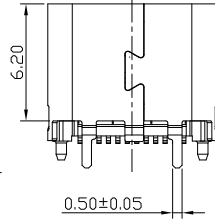
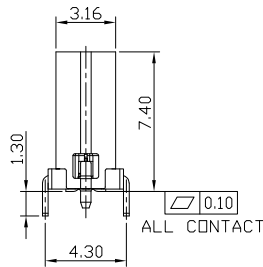
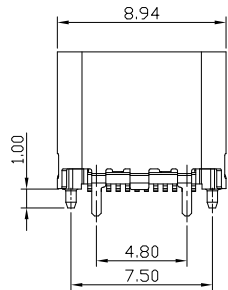
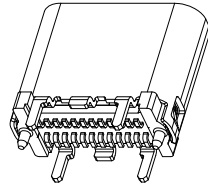
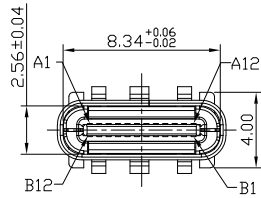

WITH PICK UP COVER

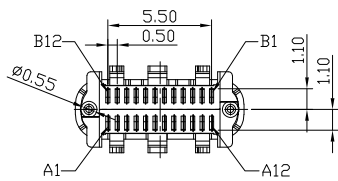

NOTES:

1.ELECTRICAL CHARACTERISTICS:

- VOLTAGE RATING: 5 V DC/AC (RMS, max)  
CURRENT RATING: 5 AMPS, FOR TOTAL VBUS/GND PINS;  
1.25AMPS FOR CC PIN,0.25 AMPS, FOR ALL OTHER CONTACT.  
LLCR:  
VBUS & GND PINS AND OTHER PINS: 40mΩ/PIN MAX.  
SHIELD:50mΩ/MAX.  
LLCR MAX. CHANGE OF ALL PINS: 10mΩ.
- INSULATION RESISTANCE: 100MΩ MIN.
- CONTACT RESISTANCE: 40mΩ Max.
- WITHSTANDING VOLTAGE: AC 100V FOR 1 MINUTE.
- OPERATING TEMPERATURE: -25°C ~ 85°C

2.MECHANICAL CHARACTERISTICS:

- MATING FORCE: 5N~20N.
- UNMATED FORCE: 8N~20N.
- DURABILITY: 10,000 CYCLES.

3.DIMENSIONS MARKED "▼"  
TO BE CHECKED BY Q.C & IPQC.

4.PART NO.

USCF-241N-4BQU36

W:WHITE  
B:BLACK

- 1:Au 1U"
- 2:Au 3U"
- 5:Au 15U"
- 6:Au 30U"
- 1:PBT
- 2:PA6T
- 3:PA9T
- 4:LCP

Bill of materials:

NO	PARTS	MATERIAL	QTY	FINISHING					
6	CAP	LCP+30%GF	1	UL94V-0	X	±0.30	X.*	±10°	UNITS mm
5	EMI PLATE	STAINLESS STEEL	1		XX	±0.20	.X*	±8°	MAT'L
4	FRONT SHELL	STAINLESS STEEL	1	PLATED NICKEL	XXX	±0.10	.XX*	±5°	SEE NOTE
3	MID PLATE	STAINLESS STEEL	1						FINISH
2	TERMINAL	COPPER ALLOY	24	PLATED GOLD/TIN					SEE NOTE
1	HOUSING	LCP+30%GF	1	UL94V-0					Q'TY
NO	PARTS	MATERIAL	QTY	FINISHING					

THESE DRAWINGS AND SPECIFICATIONS ARE THE PROPERTY OF ACCURATE INNOTECH INC AND SHALL NOT BE REPRODUCED, COPIED OR USED IN ANY MANNER WITHOUT THE PRIOR WRITTEN CONSENT OF ACCURATE INNOTECH INC.

<b>雅安科技有限公司</b> <b>ACCURATE INNOTECH INC.</b>			
TITLE: USB TYPE CF 24P 直立式SMT H=7.4 外壳脚长1.3		PART NO: USCF-24XN-4BQU36	
DR: Ricky 2023/05/20		DWG NO: AII-QU36	
CHKD: Ricky 2023/05/20		SCALE	SHEET
APPD:		1:1	1/1
		REV. B	CUSTOMER DRAWING