

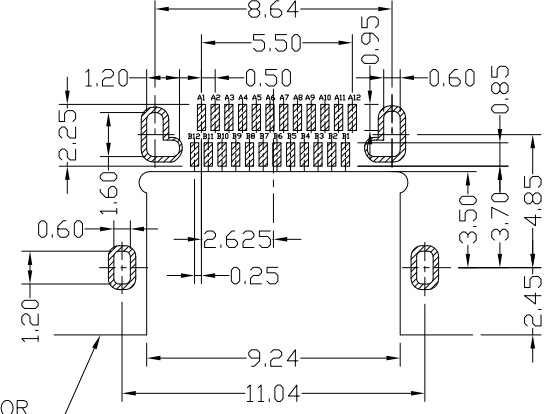

RoHS Compliant
2002/95/EC

REV.	ECN. NO.	APPD.

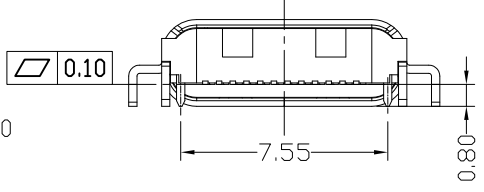
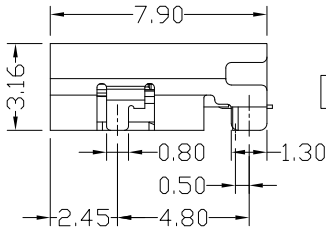
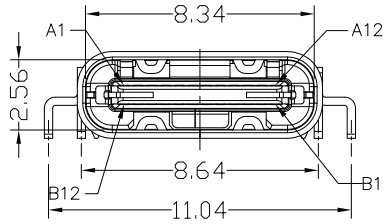
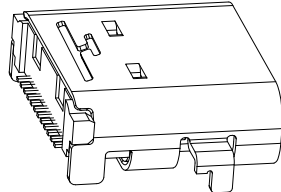
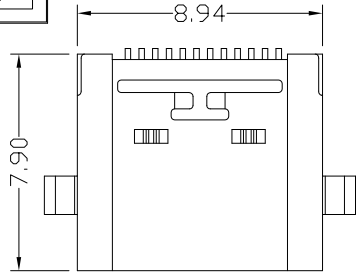

CONNECTOR FRONT EDGE

RECOMMENDED P.C.B. LAYOUT
TOLERANCE UNSPECIFIED ±0.05mm

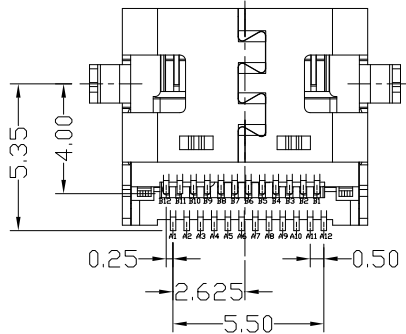

A1	GND	B12	GND
A2	SSTXP1	B11	SSRXP1
A3	SSTXN1	B10	SSRXN1
A4	VBUS	B9	VBUS
A5	CC1	B8	SBU2
A6	DP1	B7	DN2
A7	DN1	B6	DP2
A8	SBU1	B5	CC2
A9	VBUS	B4	VBUS
A10	SSRXN2	B3	SSTXN2
A11	SSRXP2	B2	SSTXP2
A12	GND	B1	GND
PIN	SIGNAL NAME	PIN	SIGNAL NAME

- NOTES:
- ELECTRICAL:
 - CURRENT RATING: 3AMP MAX;
 - INSULATION RESISTANCE: 100MΩ MIN 250V DC;
 - CONTACT RESISTANCE: 30mΩ MAX;
 - WITHSTANDING VOLTAGE: 250V AC;
 - OPERATING TEMPERATURE: -30°C TO +85°C.
 - Mechanical:
 - Mating Force: 5N~20N
 - Unmating Force: 8N~20N
 - DIMENSIONS MARKED "▼"
TO BE CHECKED BY Q.C & IPQC.

4.PART NO.
USCF-24*N-4BV602
W:WHITE
B:BLACK
1:Au 1U*
2:Au 3U*
5:Au 15u*
6:Au 30U*

5	SHRAPNEL	STAINLESS STEEL	1		.X ±0.30	.X* ±1*	UNITS mm
4	HOOK	STAINLESS STEEL	1	PLATED TIN	.XX ±0.20	.XX*	MAT'L
3	SHELL	STAINLESS STEEL	1	PLATED NICKEL	.XXX ±0.10	.XXX*	SEE NOTE
2	TERMINAL	COPPER ALLOY	24	PLATED GOLD			FINISH
1	HOUSING	LCP+30%GF	1	UL94V-0			SEE NOTE
NO	PARTS	MATERIAL	QTY	FINISHING			Q'TY

THESE DRAWINGS AND SPECIFICATIONS ARE THE PROPERTY OF ACCURATE INNOTECH INC AND SHALL NOT BE REPRODUCED, COPIED OR USED IN ANY MANNER WITHOUT THE PRIOR WRITTEN CONSENT OF ACCURATE INNOTECH INC

雅安科技有限公司
ACCURATE INNOTECH INC.

TITLE: USB 3.1 TYPE CF 短体7.9 双排24P 沉板0.8 无弹

PART NO.: USCF-24XN-4BV602

DR: Ricky 2017/12/11

DWG NO.: AII-V602

CHKD: Ricky 2017/12/11

APPD:

SCALE: 1:1 SHEET: 1/1 REV: B CUSTOMER DRAWING