

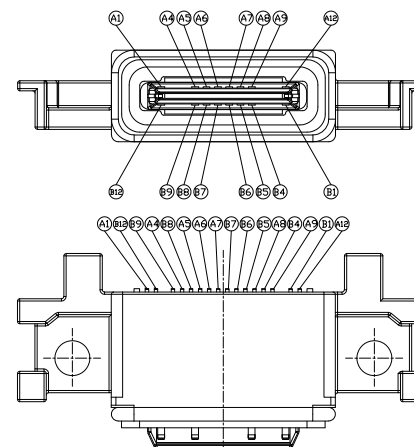

RoHS Compliant
2002/95/EC

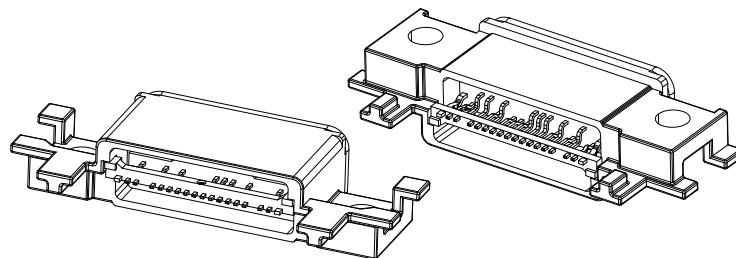

REV.	ECN.	NO.	APPD.

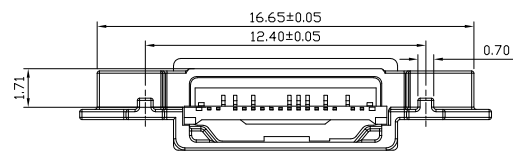

A1	GND	B12	GND
A4	VBUS	B9	VBUS
A5	CC1	B8	SBU2
A6	DP1	B7	DN2
A7	DN1	B6	DP2
A8	SBU1	B5	CC2
A9	VBUS	B4	VBUS
A12	GND	B1	GND
PIN	SIGNAL NAME	PIN	SIGNAL NAME

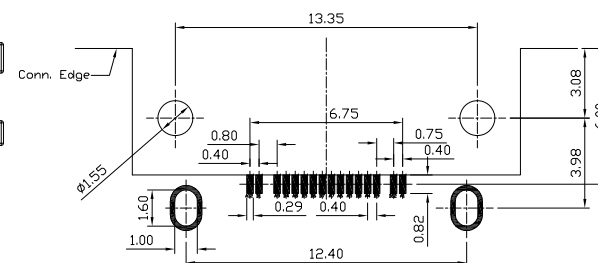
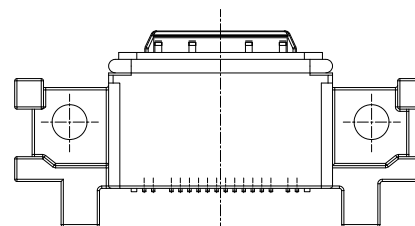
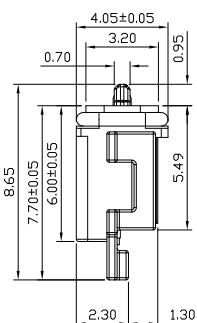
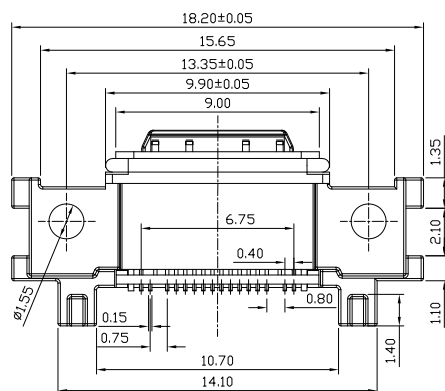

RECOMMENDED PCB LAYOUT(TOP VIEW)
GENERAL TOLERANCES:±0.05

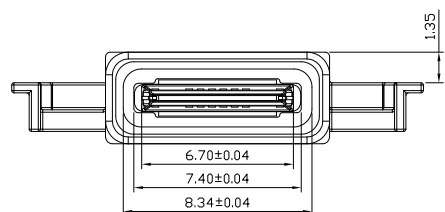

NOTES:

1.ELECTRICAL:

- 1)CURRENT RATING: 3AMP MAX 30V DC;
- 2)INSULATION RESISTANCE: 100mΩ MIN;
- 3)CONTACT RESISTANCE: INITIAL 40mΩ MAX;
- 4)WITHSTANDING VOLTAGE: 100V AC FOR 1 MINUTE.
- 5)OPERATING TEMPERATURE:-30°C TO +80°C.

2.Mechanical:

- 1)Mating Force: 5N~20N MAX.
- 2)Unmating Force: 8N~20N MIN.
- 3)Durability: ≥8,000 CYCLES.;

3.DIMENSIONS MARKED "▼"

TO BE CHECKED BY Q.C & IPQC.

4.PART NO.

UWCF-161N-3BVG30

W:WHITE
B:BLACK

1:Au 1U"
2:Au 3U"
5:Au 15U"
6:Au 30U"

1:PBT
2:PA6T
3:PA9T
4:LCP

Bill of materials:

NO	PARTS	MATERIAL	QTY	FINISHING	X.	±0.50	Angle ±1°	UNITS	mm
4	MID PLATE	STAINLESS STEEL	1		X.	±0.20		MAT'L	
3	SHELL	ZINC ALLOY	1	PLATED NICKEL	XX	±0.10		SEE NOTE	
2	TERMINAL	COPPER ALLOY	16	PLATED GOLD	XXX	±0.03		FINISH	
1	HOUSING	PA9T+30%GF	1	UL94V-0				SEE NOTE	
								Q'TY	

雅安科技有限公司
ACCURATE INNOTECH INC.

TITLE: USB TYPE CF WATERPROOF 单排16PIN 沉板1.71

PART NO.: UWCF-16XN-3BVG30

DR: Ricky 2020/09/03

DWG NO.: AII-VG30

CHKD: Ricky 2020/09/03

SCALE: 1:1

SHEET: 1/1

REV.: B

CUSTOMER DRAWING

THESE DRAWINGS AND SPECIFICATIONS ARE THE PROPERTY OF ACCURATE INNOTECH INC AND SHALL NOT BE REPRODUCED, COPIED OR USED IN ANY MANNER WITHOUT THE PRIOR WRITTEN CONSENT OF ACCURATE INNOTECH INC.

